

- Standard
- Optional
- Non disponibile - Not available

	Express	Express XL
Dimensioni macchina (mm, P/L/H) Machine dimensions (mm, P/L/H)		
Peso (kg) Weight (kg)	320	330
Carrozzeria in Frame made of	acciaio inox stainless steel	acciaio inox stainless steel
Alimentazione elettrica (standard) Electrical supply (standard)	3 x 400 V + N + PE - 50 Hz	3 x 400 V + N + PE - 50 Hz
Pompa alto vuoto lubrificata (m ³ /h) Lubricated high vacuum pump (m ³ /h)	40 63	63
Potenza assorbita (kW) configurazione standard Power supplied (kW) in standard configuration	1,7 -> 3	1,85 -> 3,1
Massima fascia bobina film (mm) Maximum reel film width (mm)	320	480
Massimo diametro esterno bobina film (mm) Max reel film diameter (mm)	240	240
Massima dimensione vaschette (mm) Maximum trays dimension (mm)	 n°1 180x250 H max 30 (standard) H max 50 (optional)	 n°1 390x310 n°2 185x310 n°3 120x310 n°4 80x310 H max 100
Avanzamento e riavvolgimento automatico film Automatic film feeding and rewinding	✓	✓
Nastro alimentazione vaschette (mm) Tray feeding conveyor (mm)	750	1025
Gestione macchina Operating system	PLC con sensore digitale integrato PLC with integrated vacuum sensor	scheda elettronica Yang con sensore digitale e 10 programmi Yang electronic panel with digital vacuum sensor and 10 programs
Numero cicli macchina Cycle/min	7/15	4/15
Versione PACK (senza tecnologia SOTTOVUOTO) PACK version (NO-VACUUM technology)	●	●
Aria compressa richiesta Compressed AIR	6/8	6/8

- Altre opzioni**
Other options
- Fotocellula presenza vaschetta
Tray detection photocell
 - Fotocellula centratura film stampato
Printed film registration
 - Polmone gas
Gas buffer tank
 - Carrello cambio stampo
Mould changing wagon
 - Filtro liquidi/polveri
Liquids/powders filter
 - La confezionatrice a fine linea può essere completata da: etichettatrice, pesatrice, applicatore coperchi preformati, ecc.
The tray packaging machine can be completed with end of line functions: e.g. labelling machine, weighing machine, pre shaped lid applicator etc.



Ci riserviamo il diritto di modificare e migliorare le macchine senza nessun preavviso / We reserve the right to improve our machines without warning - ed. 01/2011 -



**EXPRESS
PERSEUS**



YANG Srl
via al Bassone, 30
22100 - **COMO** - Italy

☎ (+39) 031.888.011 ☎ (+39) 031.888.050
✉ info.export@yang.it ✉ info.italia@yang.it
🌐 www.yang.it 🌐 www.yang.eu



- Standard
- Optional
- Non disponibile - Not available

	Perseus
Dimensioni macchina (mm, P/L/H) Machine dimensions (mm, P/L/H)	
Peso (kg) Weight (kg)	440
Carrozzeria in Frame made of	acciaio inox stainless steel
Alimentazione elettrica (standard) Electrical supply (standard)	3 x 400 V + N + PE - 50 Hz
Potenza assorbita (kW) configurazione standard Power supplied (kW) in standard configuration	2,1 -> 3,9
Aria compressa richiesta (bar) Compressed air (bar)	6/8
Pompa alto vuoto lubrificata (m ³ /h) Lubricated high vacuum pump (m ³ /h)	63 100 / 200 / 300
Massima fascia bobina film (mm) Maximum reel film width (mm)	480
Massimo diametro esterno bobina film (mm) Max reel film diameter (mm)	240
Massima dimensione vaschette (mm) Maximum trays dimension (mm)	 n°1 400x275 n°2 185x280 n°3 120x275 n°4 85x275 H max 110
Avanzamento e riavvolgimento automatico film Automatic film feeding and rewinding	✓
Nastro alimentazione vaschette (mm) Tray feeding conveyor (mm)	1400
Gestione macchina Operating system	PLC con sensore digitale integrato PLC with integrated vacuum sensor
Numero cicli macchina Cycle/min	5/15
Versione PACK (senza tecnologia SOTTOVUOTO) PACK version (NO-VACUUM technology)	●
Aria compressa richiesta Compressed AIR	6/8

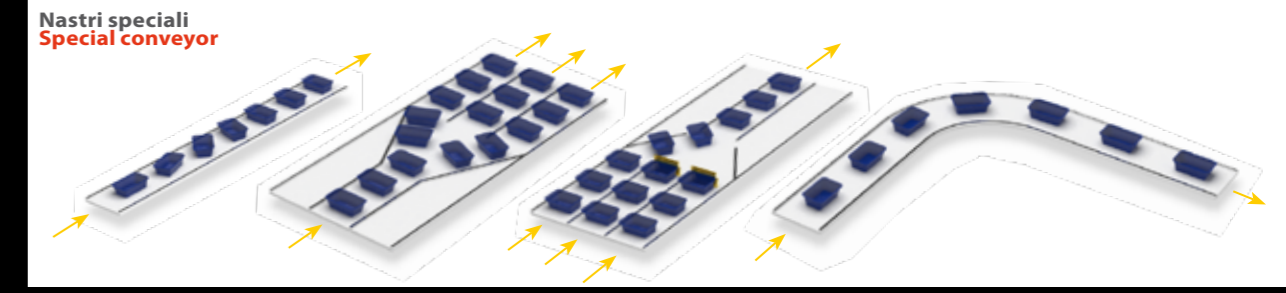

- Altre opzioni**
Other options
- Fotocellula presenza vaschetta
Tray detection photocell
 - Fotocellula centratura film stampato
Printed film registration
 - Polmone gas
Gas buffer tank
 - Dosatori prodotto liquido - solido
Dosing system (liquid and solid product)
 - Disimpiantatori di vaschette
Tray denester
 - Marcatore data scadenza
Expiry date markers
 - Nastro di scarico motorizzato con convogliatori per etichettatura
Motorized outfeed belt with optional labelling conveyor
 - Filtro liquidi/polveri
Liquids/powders filter
 - Carrello cambio stampo
Mould changing wagon
 - La confezionatrice a fine linea può essere completata da: etichettatrice, pesatrice, applicatore coperchi preformati, ecc.
The tray packaging machine can be completed with end of line functions: e.g. labelling machine, weighing machine, pre shaped lid applicator etc.



**Tecnologie
Technologies**



Express XL



Grandi prestazioni in poco spazio
High performances in a reduced space



Max dimensione vaschette: 385x275 mm H100
Cambio stampo rapido senza l'impiego di utensili
Doppia o tripla linea di vaschette standard
Fotocellula centratura film stampato



Express



Confezionatrici di vaschette in sottovuoto e atmosfera protettiva
Tray Heat Sealing machine with both vacuum and gas

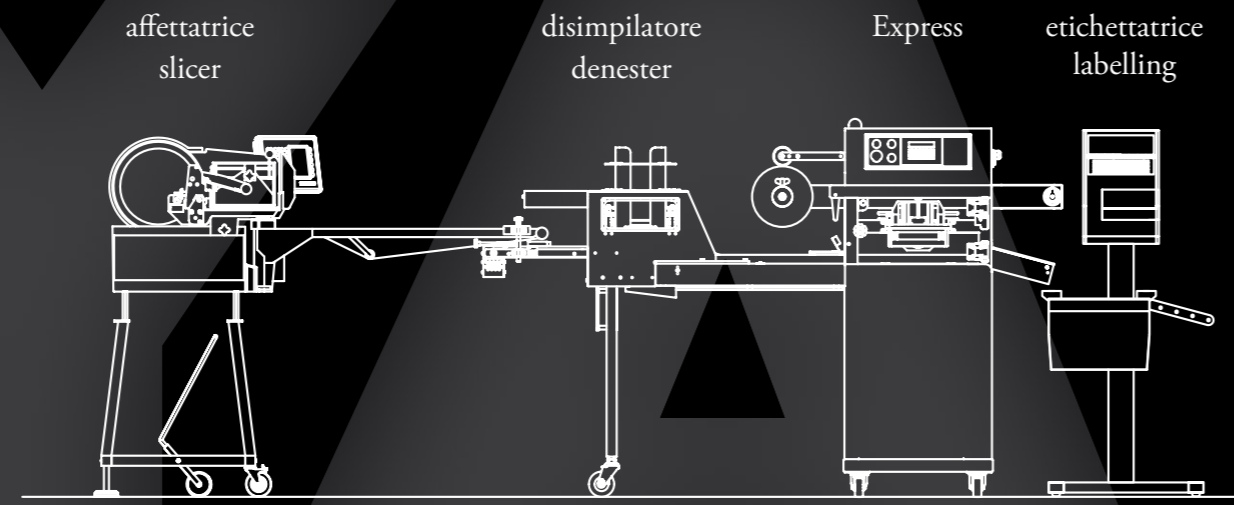

affettatrice slicer disimpilatore denester Express etichettatrice labelling

Express linea automatica
Express automatic

Caratteristiche comuni Common Features



Scheda elettronica Yang di nuova generazione con 10 programmi, 6 lingue e diagnostica.
New electronic board with 10 programs, 6 languages, visual alarm display and incorporated diagnostic page.



Camera del vuoto "vestita" intorno alla vaschetta per un grande risparmio di gas.
Vacuum chamber designed to maximize the number of trays per cycle with gas saving features



Un'attraente confezione accresce il valore del prodotto
Attractive packaging increases product value



Un potente PLC con vacuostato integrato gestisce tutti i processi.
All functions are PLC controlled including vacuum and gas pressure.



Disimpilatore di vaschette con possibilità di cambio rapido del formato.
Automatic tray denester with magazine for quick size changeover.

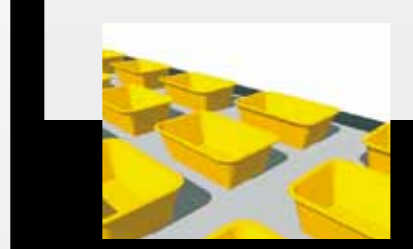

Doppia, tripla o quadrupla linea di vaschette standard.
Double, triple or quadruple tray lines.



La macchina offre, tra i propri standard, il cambio stampo rapido senza l'impiego di utensili, semplificando le operazioni di sanificazione.
The machine offers as standard easy and fast die change without tools and simple cleaning.



Optional Trasferimento termico.
Option for thermal transfer.



Traslatore da una a più vaschette.
Translator from one to several trays.

Perseus



Perseus è la nostra confezionatrice in linea per sigillare vaschette preformate in differenti materiali, con film compatibili in bobine.

The Perseus packaging machine is an inline system which is capable of sealing preformed trays of different materials with compatible film.

La Perseus è stata progettata con una tecnologia tale da ridurre al minimo la manutenzione e, grazie alla sua accessibilità totale, la pulizia della macchina e gli interventi di assistenza e manutenzione risultano semplici e agevoli.

The Perseus has been designed using the latest technology to reduce maintenance and make the machine extremely user friendly.



Special Applications

