

RICCIARELLI

PACKAGING MACHINERY

Pesatrice Multiteste mod. FCBS10

Multi-head Weigher mod. FCBS10

Pesatrice a testate multiple dotata di 10 unità di pesatura, comandate da motori "passo-passo". Disponibile in versione standard e acciaio inox.

Caratteristiche principali

- Microprocessori indipendenti posti su ogni cella.
- Collegamento tra le varie teste e l'unità centrale mediante bus di campo seriale CAN-BUS.
- Ricerca della combinazione mediante DSP (Digital Signal Processor).
- Versione allargata (FCBS10L) per grossi volumi.

Dati Tecnici

Gamma di peso :	da 20 a 1000 gr.
Max. velocità meccanica:	70 pesate al minuto
Volume max. pesata (Std):	8.750 cc.
Max. lungh. singolo pezzo:	80 mm.
Potenza installata:	3,5 Kw.

Dati Tecnici mod. FCBS10L

Gamma di peso:	da 100 a 5000 gr.
Max. velocità meccanica:	50 pesate al minuto
Volume max. pesata (Std):	17.000 cc.
Max. lungh. singolo pezzo:	150 mm.
Potenza installata:	3,5 Kw.

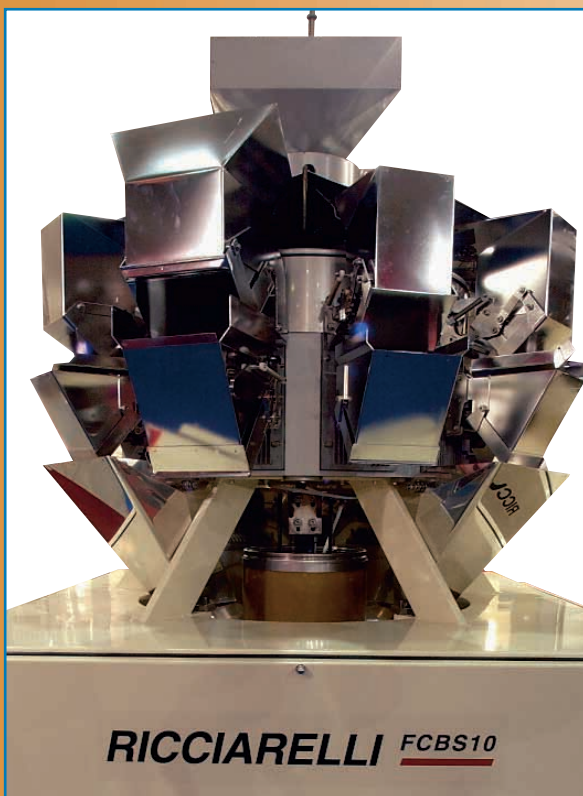

Multi-head weigher with 10 weighing heads, controlled by independent stepper motor drive. Available in standard and stainless steel version.

Main Features

- Independent microprocessors placed on each cell.
- Connection between the heads and the central unit is made with a CAN-BUS.
- Combination weighing system is based on digital signal processor (DSP) technology.
- Large version (FCBS10L) for high volumes.

Technical data

Weight range:	from 20 to 1000 g.
Max. mechanical speed:	70 weights/min.
Max. volume at weight cycle (Std):	8.750 cc.
Max. length of single piece:	80 mm.
Installed Power :	3,5 Kw.

Technical data FCBS10L

Weight range:	from 100 to 5000 g
Max. mechanical speed:	50 weights/min.
Max. volume at weight cycle (Std):	17.000 cc.
Max. length of single piece:	150 mm.
Installed Power :	3,5 Kw.

RICCIARELLI

PACKAGING MACHINERY

SISTEMAS DE PESAJE

SYSTEMES DE PESAGE

Pesadora Multicabezales mod. FCBS10 Peseuse Associative mod. FCBS10

Pesadora multicabezales a 10 cabezales de pesado, mandados por motores "paso a paso", disponible en versión estandar y acero inoxidable.

Características principales

- Control de cada cabezal en todas sus funciones por un propio microprocesador.
- Conexión entre las varias cabezales y unidad central por medio de bus de campo serial CAN-BUS.
- Búsqueda de la combinación a través DSP (Digital Signal Processor).
- Versión "más ancha" (FCBS10L) para grandes volúmenes.

Datos Técnicos

Gama de peso:	de 20 a 1000 gr.
Velocidad max. (mecánica):	70 pesadas al minuto
Volumen max. pesada (Std):	8.750 cc.
Longitud max. producto:	80 mm.
Potencia instalada:	3,5 Kw.

Datos Técnicos FCBS10L

Gama de peso :	de 100 a 5000 gr.
Velocidad max. (mecánica):	50 pesadas al minuto
Volumen max. pesada (Std):	17.000 cc.
Longitud max. producto:	150 mm.
Potencia instalada:	3,5 Kw.

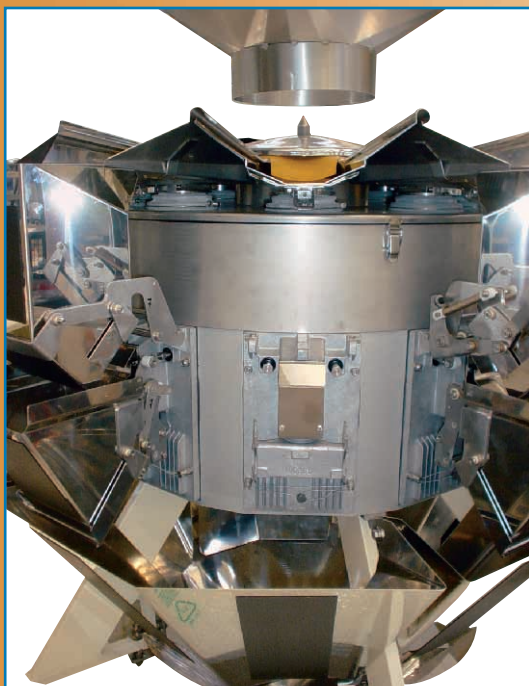
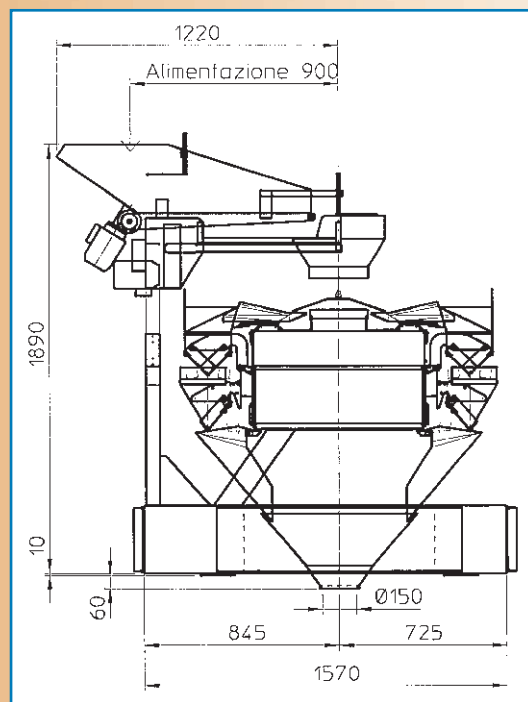

Peseuse à têtes multiples avec 10 têtes de pesage commandées par des moteurs à pas. En version standard ou acier inoxydable.

Fonctions principales

- Microprocesseurs indépendants placés sur chaque tête de pesage.
- Liaison entre les têtes et l'unité centrale avec bus de champs sériel CAN-BUS.
- Recherche de la combinaison avec DSP (Digital Signal Processor).
- Version large (FCBS10L) pour gros volumes.

Données Techniques

Gamme de poids:	de 20 à 1000 g.
Vitesse max. à vide:	70 pesées/min.
Volume max. chaque pesée (Std):	8.750 cc.
Longueur max. du produit:	80 mm.
Puissance installée :	3,5 Kw.

Données Techniques FCBS10L

Gamme de poids:	de 100 à 5000 g.
Vitesse max. à vide:	50 pesées/min.
Volume max. chaque pesée (Std):	17.000 cc.
Longueur max. du produit:	150 mm.
Puissance installée:	3,5 Kw.

All illustrations and technical specifications are subject to change without prior notice

RICCIARELLI S.p.A.

Via U. Mariotti, 143 - Z.I. S. Agostino - 51100 Pistoia (Italy)
Tel. +39 0573 44571 - Fax +39 0573 933223
e-mail: info@ricciarellispa.it
http://www.ricciarelli-packaging.com

Local Agent

