

RICCIARELLI

PACKAGING MACHINERY

Pesatrice Multiteste mod. FCBS14 Multi-head Weigher mod. FCBS14

Pesatrice a testate multiple dotata di 14 unità di pesatura, comandate da motori "passo-passo". Disponibile in versione standard e acciaio inox.

Caratteristiche principali

- Microprocessori indipendenti posti su ogni cella.
- Collegamento tra le varie teste e l'unità centrale mediante bus di campo seriale CAN-BUS.
- Ricerca della combinazione mediante DSP (Digital Signal Processor).
- Versione allargata (FCBS14L) per grossi volumi.

Dati Tecnici

Gamma di peso:	da 20 a 1000 gr.
Max. velocità meccanica:	120 pesate al minuto
Volume max. pesata (Std):	7.000 cc.
Max. lungh. singolo pezzo:	80 mm.
Potenza installata:	4,5 Kw.

Dati Tecnici mod. FCBS14L

Gamma di peso:	da 100 a 5000 gr.
Max. velocità meccanica:	90 pesate al minuto
Volume max. pesata (Std):	14.000 cc.
Max. lungh. singolo pezzo:	150 mm.
Potenza installata:	4,5 Kw.

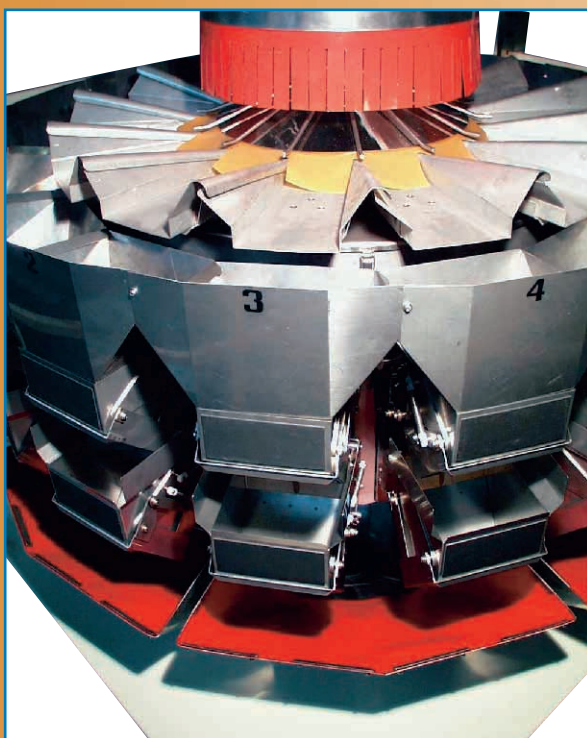
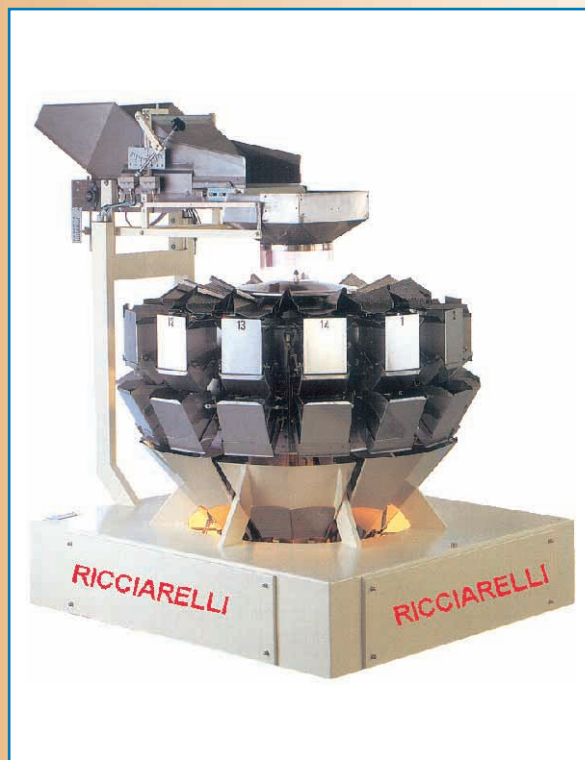

Multi-head weigher with 14 weighing heads, controlled by independent stepper motor drive. Available in standard and stainless steel version.

Main Features

- Independent microprocessors placed on each cell.
- Connection between the heads and the central unit is made with a CAN-BUS.
- Combination weighing system is based on digital signal processor (DSP) technology.
- Large version (FCBS14L) for high volumes.

Technical data

Weight range:	from 20 to 1000 g.
Max. mechanical speed:	120 weights/min.
Max. volume at weight cycle (Std):	7.000 cc.
Max. length of single piece:	80 mm.
Installed Power :	4,5 Kw.

Technical data FCBS14L

Weight range:	from 100 to 5000 g
Max. mechanical speed:	90 weights/min.
Max. volume at weight cycle (Std):	14.000 cc.
Max. length of single piece:	150 mm.
Installed Power :	4,5 Kw.

RICCIARELLI

PACKAGING MACHINERY

Pesadora Multicabezales mod. FCBS14 Peseuse Associative mod. FCBS14

Pesadora multicabezales a 14 cabezales de pesado, mandados por motores "paso a paso", disponible en versión estandar y acero inoxidable.

Características principales

- Control de cada cabezal en todas sus funciones por un propio microprocesador.
- Conexión entre las varias cabezales y unidad central por medio de bus de campo serial CAN-BUS.
- Búsqueda de la combinación a través DSP (Digital Signal Processor).
- Versión "más ancha" (FCBS14L) para grandes volúmenes.

Datos Técnicos

Gama de peso:	de 20 a 1000 gr.
Velocidad max. (mecanica):	120 pesadas al minuto
Volumen max. pesada (Std):	7.000 cc.
Longitud max. producto:	80 mm.
Potencia instalada:	4,5 Kw.

Datos Técnicos FCBS14L

Gama de peso :	de 100 a 5000 gr.
Velocidad max. (mecanica):	90 pesadas al minuto
Volumen max. pesada (Std):	14.000 cc.
Longitud max. producto:	150 mm.
Potencia instalada:	4,5 Kw.

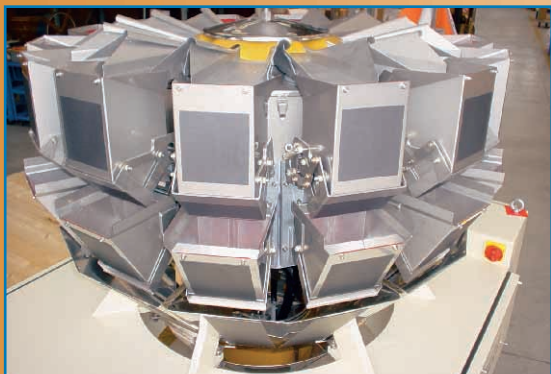
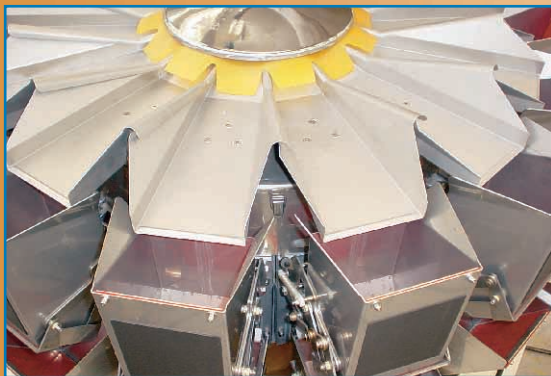
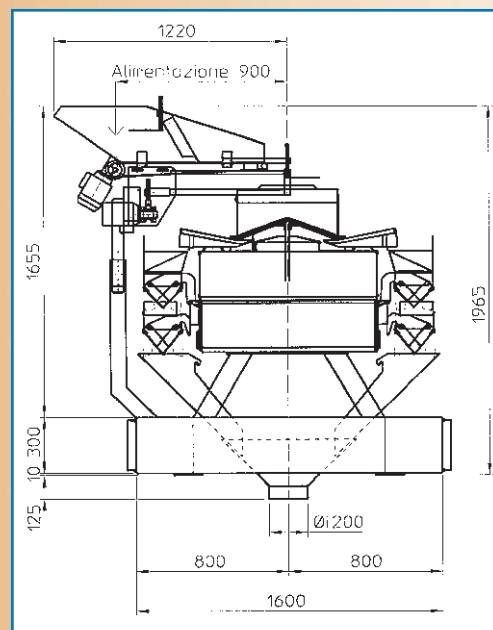

Peseuse à têtes multiples avec 14 têtes de pesage commandées par des moteurs à pas. En version standard ou acier inoxydable.

Fonctions principales

- Microprocesseurs indépendants placés sur chaque tête de pesage.
- Liaison entre les têtes et l'unité centrale avec bus de champs sériel CAN-BUS.
- Recherche de la combinaison avec DSP (Digital Signal Processor).
- Version large (FCBS14L) pour gros volumes.

Données Techniques

Gamme de poids:	de 20 à 1000 g.
Vitesse max. à vide:	120 pesées/min.
Volume max. chaque pesée (Std):	7.000 cc.
Longueur max. du produit:	80 mm.
Puissance installée :	4,5 Kw.

Données Techniques FCBS14L

Gamme de poids:	de 100 à 5000 g.
Vitesse max. à vide:	90 pesées/min.
Volume max. chaque pesée (Std):	14.000 cc.
Longueur max. du produit:	150 mm.
Puissance installée :	4,5 Kw.

All illustrations and technical specifications are subject to change without prior notice

RICCIARELLI S.p.A.

Via U. Mariotti, 143 - Z.I. S. Agostino - 51100 Pistoia (Italy)
Tel. +39 0573 44571 - Fax +39 0573 933223
e-mail: info@ricciarellispa.it
http://www.ricciarelli-packaging.com

Local Agent



SISTEMAS DE PESAJE

SYSTEMES DE PESAGE